



HYDROGEN GAS GENERATOR SERIE ND-H2 AND PAR-H2



The ND-H2 and PAR-H2 hydrogen generators use the latest polymer electrolyte membrane (PEM) technology to produce pure hydrogen.

The ND-H2 series use a desiccant cartridge and the PAR-H2 unit use a single column dryer with programmable automatic regeneration via an integrated clever calendar.

The ND-H2 and PAR-H2 series generators are ideal for:

- Ionization flame detector (FID)
- Carrier gas for GC e GC-MS
- Collisions on ICP-MS
- Small fuel-cell cylinder refills

Benefits and Savings

■ Improved chromatograph result

The use of hydrogen as a carrier gas allows lower temperature elution, thus extending the life of the chromatograph column. Hydrogen as a carrier gas is faster and more sensitive than the more-expensive helium. Run time savings of 25% to 35% without a decline in resolution.

■ Increased laboratory efficiency

A constant, uninterrupted gas supply of guaranteed purity eliminates interruptions of analyses to change cylinders and reduces the amount of instrument re-calibrations required.

■ Improved safety

The very limited internal volume (less than 50 ml) allows safe use of the gas generators where the use of cylinders is risky or prohibited.

The application of tested safety technologies stops the unit in the event of leaks or malfunctions

■ Simple installation

Gas generators can be installed in the laboratory, on or under a bench, eliminating the need for long gas lines from cylinders secured elsewhere.

Standard Features

- ND-H2 models available : 120,180, 260, 400, 500 and 650 cc/min
- PAR-H2 models available : 120,180, 260, 400, 500, 650, 800, 900 cc/min
- ND-H2 Purity > 99.9995%
- PAR-H2 Purity > 99.9999%
- Pressure up to 12 bar, on request 16 bar
- Patented gas/water separator electronically controlled
- LCD touch screen : real time outlet pressure, water quality, water level, autodiagnosics with alarms
- Remote PC monitoring in standard via RS232 or RS485 to interface the unit with customer's PC software
- Water tank protected and filtered
- Autorefill included in standard
- Capabilities allowing to work in parallel mode
- Remote wireless display control in option

HYDROGEN GAS GENERATOR SERIE ND-H2 AND PAR-H2

Hydrogen is produced using distilled or deionised water from hydrolysis, through a polymer membrane.

Electrolytic dissociation separates the water into its two main components: hydrogen ready for analytical use, and oxygen that is released into the air.

No acid nor alkaline solutions are used in the hydrogen generation cycle.

ND-H2 Series use a desiccant cartridge which needs to be refilled or replaced when saturated

PAR-H2 Series use a single column dryer with programmable automatic regeneration via an integrated clever calendar

The exclusive parallel working mode option allows up to 10 units to be connected, producing flow-rates of up to 6,5L/min for ND-H2 series and 9 L/min for PAR-H2 series!

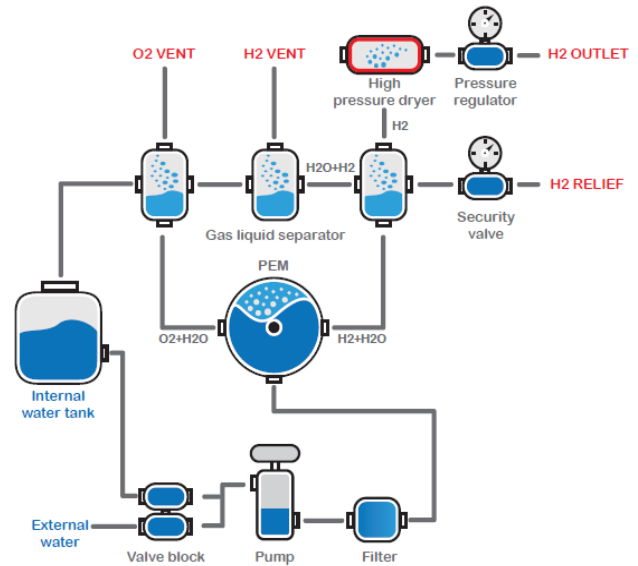

Technical Specifications

Models	ND-H2-120	ND-H2-180	ND-H2-260	ND-H2-400	ND-H2-500	ND-H2-650	N/A	
	PAR-H2-120	PAR-H2-180	PAR-H2-260	PAR-H2-400	PAR-H2-500	PAR-H2-650	PAR-H2-800	PAR-H2-900
H2 flow rate cc/min	120	180	260	400	500	650	800	900
H2 purity	> 99.9995% for ND series and > 99.9999% for PAR series							
Delivery pressure	1 - 12 barg (16 barg on request)							
Dryer	ND-H2 : desiccant cartridge PAR-H2 : single column dryer with programmable automatic regeneration via an integrated clever calendar							
Internal water tank	2,3 liters with autorefill included							
Temperature range	From 5°C to 35°C							
LCD touch screen	Resolution 128x64 touch screen (operating parameters, system status, alarms)							
In series	communication port : RS-232, RS-485, USB, LAN							
Options	- Remote wireless display control - Possible to work in parallel mode							
Water quality	Deionised or distilled > 10MΩ							
Dimensions (L x H x P)	30x43x43 cm							
Outlet port	1/8 Swagelock							
Weight	From 15 to 25kg depends of model							
Power consumption	From 200W to 800W depend of model							
Certification	CE							